



www.omsvibro.com

OMS SIDE GRIP VIBRO HAMMER

SG SERIES

Excavator Mounted Vibro Hammer
30° Tilting and 360° Rotating



POWERFUL VIBRATORY PILE DRIVING EQUIPMENT BY **OMS**

Manufacturer of Pile Driving Equipment for over 35 years!

Why Choose the OMS?

OMS offers its nature-respecting and sustainable solutions, which are part of our mission to our customers and business partners in the best way with its quality and the environment of trust it provides. Also, OMS is growing rapidly by including new dealers in its structures while continuing to have a say in international trade. These are the top reasons why OMS is preferred and why we are getting closer to our vision of being situated in the most reliable and respected position in the sector and being the "brand of the future" day by day.

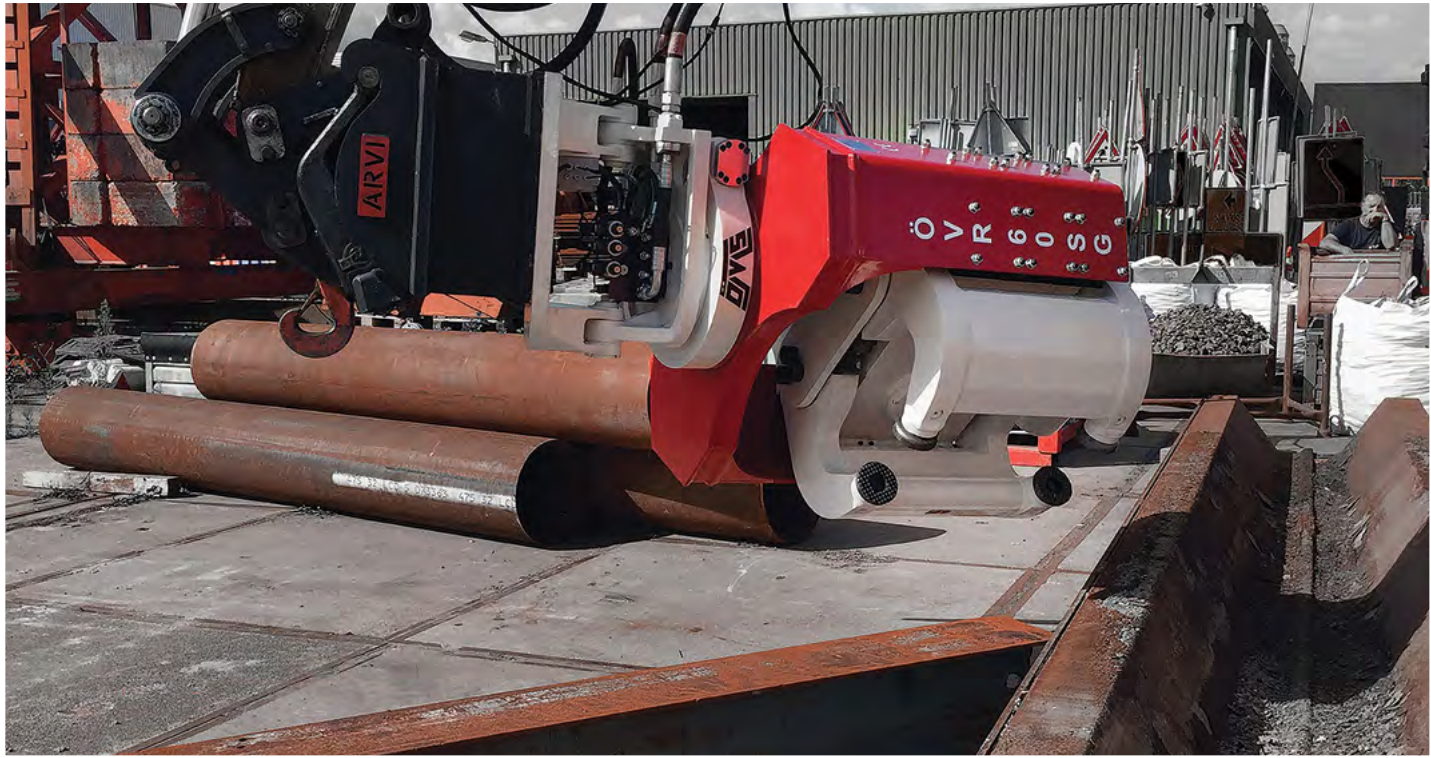

SG Series Excavator Mounted Side Grip Vibro Hammer

OMS Side Grip Vibro Hammer Features	4
OMS Side Grip Vibro Hammer System.....	7
OMS Side Grip Pile Arms.....	10
OMS Side Grip Bottom Clamp	11
Selection Guide For Side Grip Vibro Hammer	12
Usage of Side Grip Pile Driver	13
Technical Specifications	14

OMS EXCAVATOR MOUNTED SIDE GRIP VIBRO HAMMER

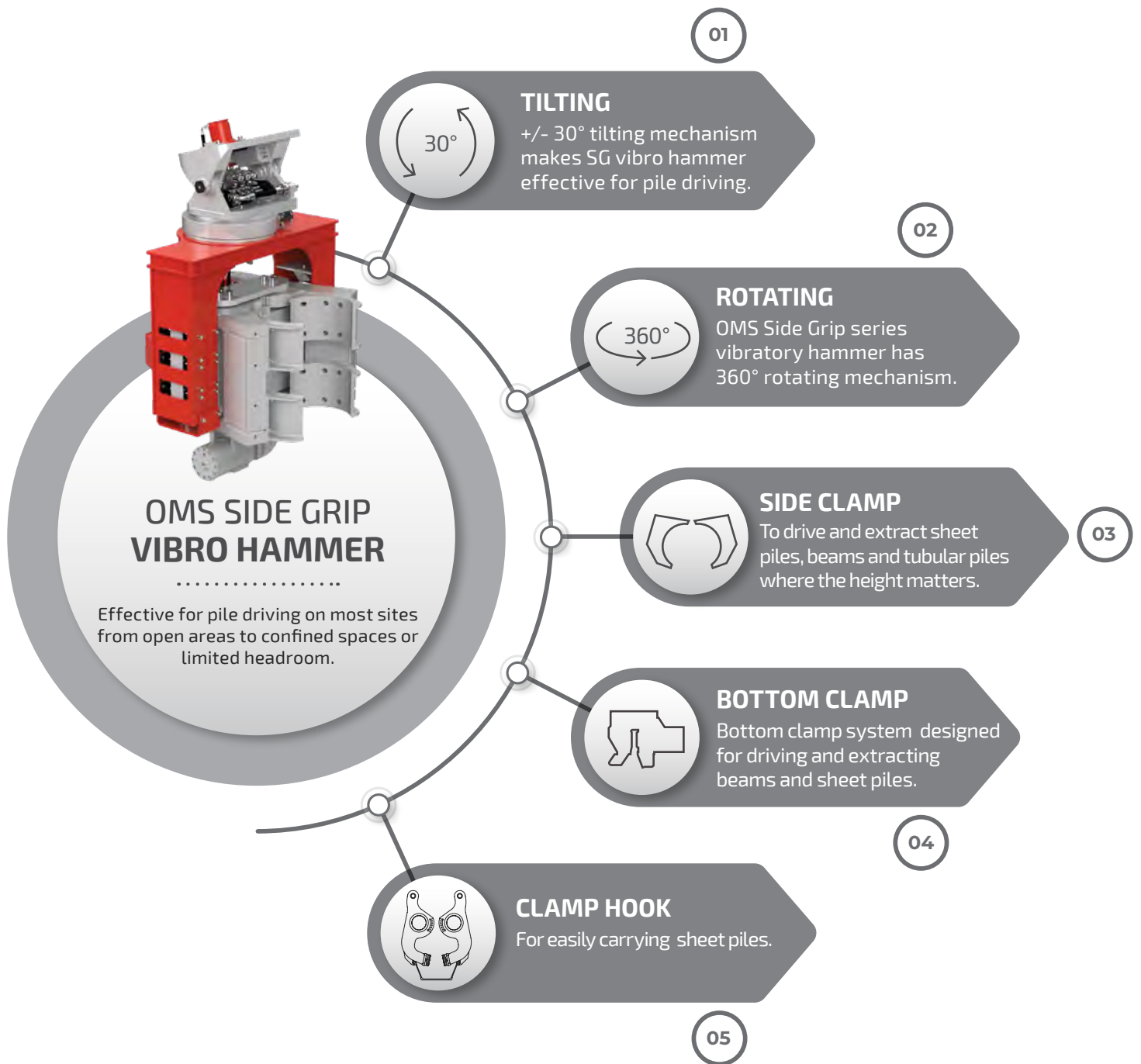



OMS SIDE GRIP VIBRO HAMMER FEATURES

01. Excavator Mounted

- Suitable for all crawler types and wheeled excavators,
- Controlled by a special electronic control system,
- Easy to operate,
- Works with excavator's standard hydraulic system.

02. Advanced Mobility

With 360° rotating system and 30° tilt mechanism, OMS vibro hammer can be worked in small areas. Side grip sheet pile drivers are capable of handling, pitching, and driving/extracting.

03. Wide Product Range

Depending on your excavator power or project requirements, OMS has different sizes and capacity OVR-SG machines. These machines have various types of arms for sheet piling, pipe piling and timber piling.

04. Quick Setup Time

OMS Side Grip Vibro Hammer can be fitted easily and quickly without any modifications required to the excavator and is controlled directly by the excavator operator.

OMS Side Grip Vibro Hammer equipped with both gripping arms/clamp and the bottom clamp. One of the clamps is located in front of vibration case, while the other one is below the vibration case. Hydraulic clamps have gripping jaws. The hydraulic cylinder operates the gripping arms with force up to 500 kN. Bottom clamp is operated with up to 440 kN, depending on clamp relief pressure. The clamps can be opened and closed directly from excavator "Joy Stick" or from the electrical remote control monitor. Clamping and un-clamping occurs in a few seconds.





OMS Side Grip Vibro Hammer can handle, pitch and drive the sheet piles. It is capable to accomplish the whole pile driving process without need for manual handling of the piles or assisting machinery.

High Performance and Pile Driving / Extracting Power!..

The equipment consists of five major components.

- Yoke
- Vibration Suppressor
- Vibration Case
- Gripping Arms
- Bottom Clamp

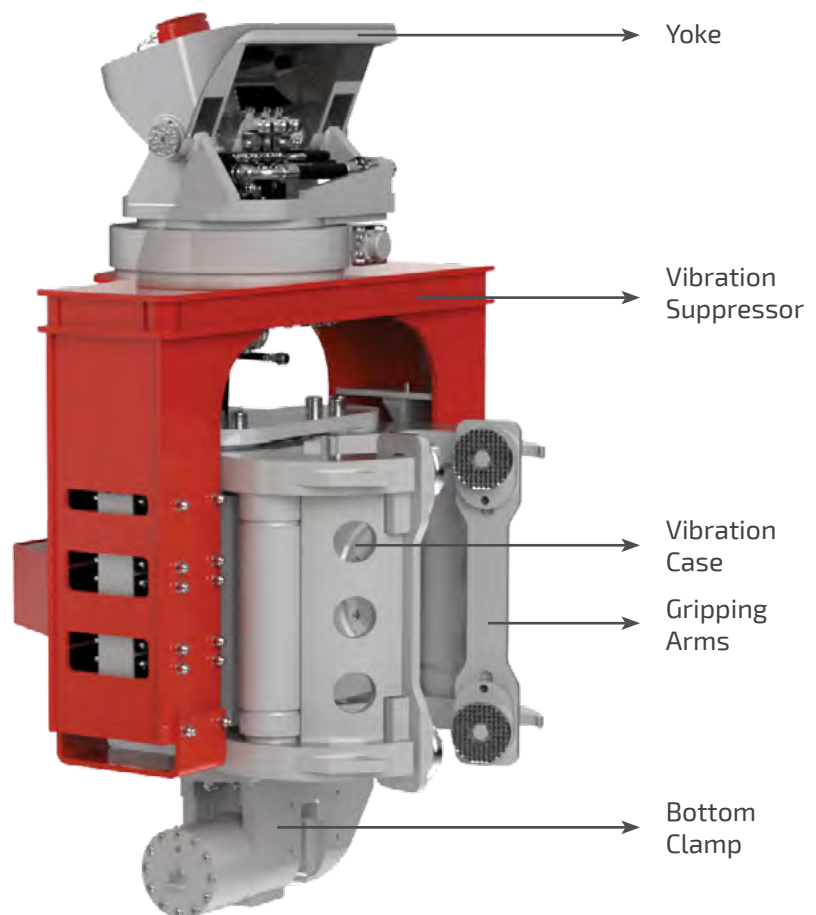

OMS SIDE GRIP VIBRO HAMMER SYSTEM

Tube pads are available various sizes from OD 160 mm to 600 mm. Each tube size requires its own tube pads in order to ensure proper operation.

Sheet pile pads are used sheet piles (w 350 - 1000) and H-beams (H250-H500)

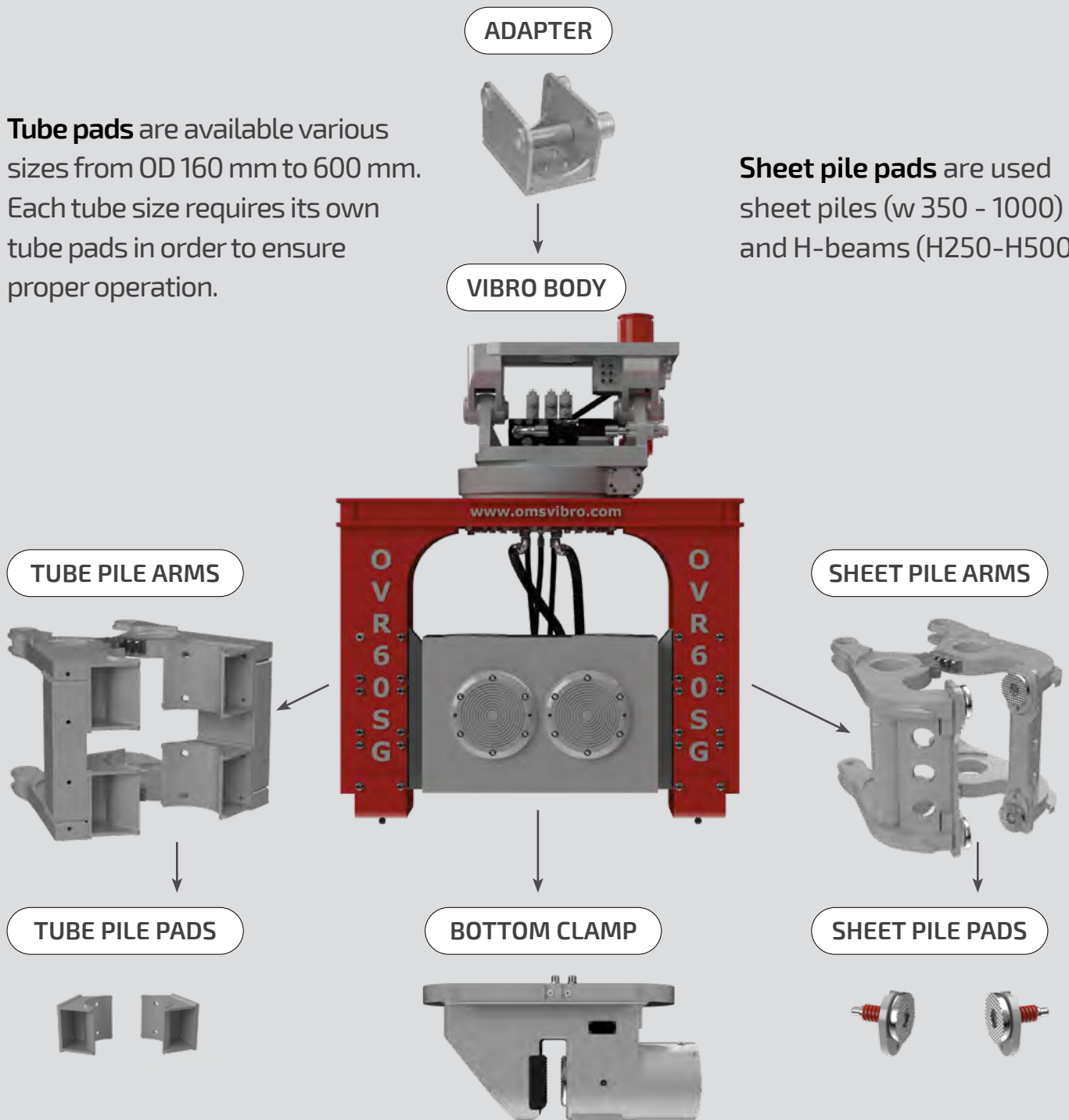

OMS Side Grip comes with pile arms and clamp system. Depending on your needs, arms can be changed. OMS Side Grip Pile Driver has two types of clamp: These are “**tube pile arms**” and “**sheet pile arms**”. With the help of these arms, many types of sheet piles, H beams, I beams and tubular piles can be used.



OVR - SG Series
Effective solution for pile driving
on low headroom and limited access sites!..





Side Grip Arms and Bottom Clamp

OMS Side Grip Vibro Hammer equipped with both gripping arms/clamp and the bottom clamp. One of the clamps is located in front of vibration case while the other one is below the vibration case.

OMS SIDE GRIP PILE ARMS

Main feature of side grip vibro hammer is **“side grip pile arms”**. Side Grip arms are designed for handling, pitching, driving and extracting of various types of piles. Depending on your needs, arms can be changed. With the help of these arms many types of sheet piles, H beams and tubular piles can be used.



Tube Pile Arms

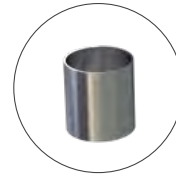

Sheet Pile Arms

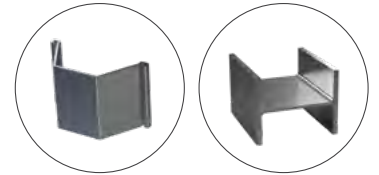

Clamping The Web



Clamp Hooks



Handling/pithing/
driving/extracting
(H - Beams)



Handling/pithing/
driving/extracting
(Sheet Piles)



Handling/pithing/
driving/extracting
(Tube Piles)

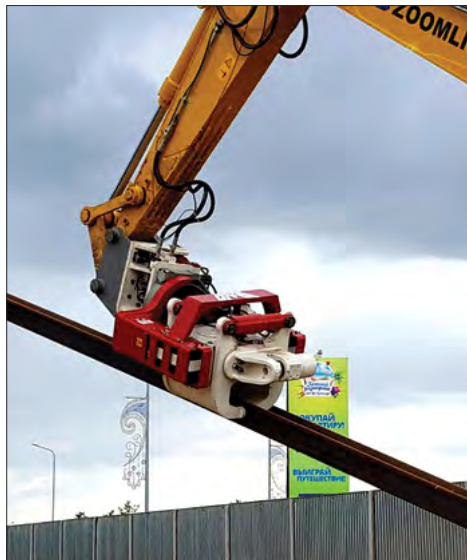

OMS SIDE GRIP BOTTOM CLAMP

The bottom clamp system is designed for driving and extracting beams and sheet piles. With the help of bottom clamp system OVR SG machines can be worked as excavator mounted standard vibro hammer system.

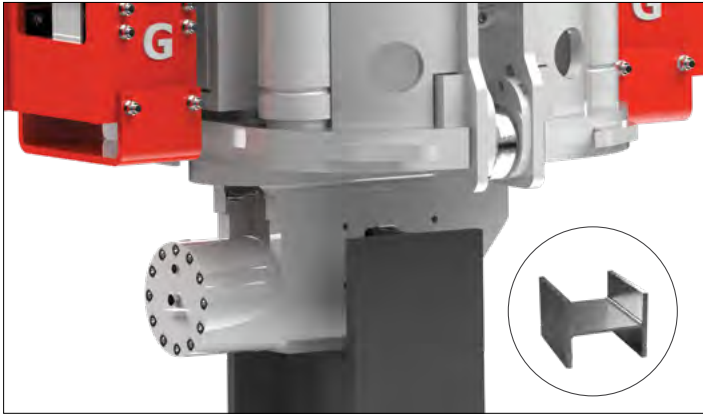

Handling/pithing/driving/extracting
(H - Beams)

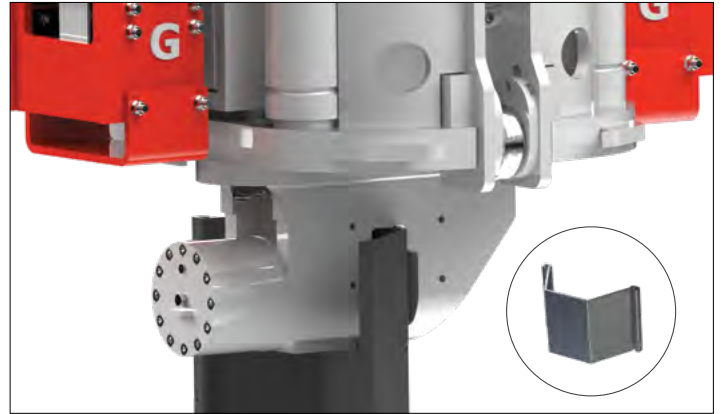

Handling/pithing/driving/extracting
(Sheet Piles)



SELECTION GUIDE FOR SIDE GRIP VIBRO HAMMER

To finalize your selection and further information please contact **OMS** technical support!

Selecting the right vibro hammer depends on some main criteria. These criteria are, excavator power, the type of pile to be driven, the driving depth and most importantly the type of soil (SPT-N Value).

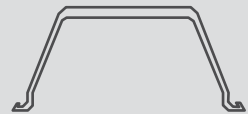
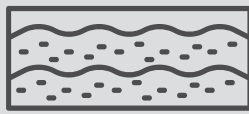
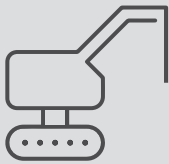

EXCAVATOR WORKING WEIGHT

The technical specifications of the excavator must meet the minimum requirements for the operation of the vibro hammer (hydraulic power “oil flow@ pressure”). Excavators lifting capacity and hydraulic system designs are also important. This information must be gathered from excavator manufacturer.

SOIL TYPE

Soil conditions must be known. Vibro hammer driving depth can be changed depending on loose, medium and very dense soil type.

TYPE OF PILE AND DRIVING DEPTH

Type of pile (H-beam, I beam, sheet pile, timber pile and tube pile etc.) is important to choose right arms for vibro hammer. Depending on pile and driving depth, vibro hammer model can be changed.

Selection Chart	OVR 40 SG	OVR 50 SG	OVR 60 SG	OVR 70 SG
Excavator Class	18-22 ton	24-26	25-30	30-36
Sheet Piles (mm)	350-800		400-1000	
H-Beams	H200-H500		H250-H500	
Timber Piles (mm)	Ø120-400		Ø160-600	
Tube Piles (mm)	Ø120-400		Ø160-600	

USAGE OF SIDE GRIP PILE DRIVER

Handling



Carrying Sheet Piles



Pitching

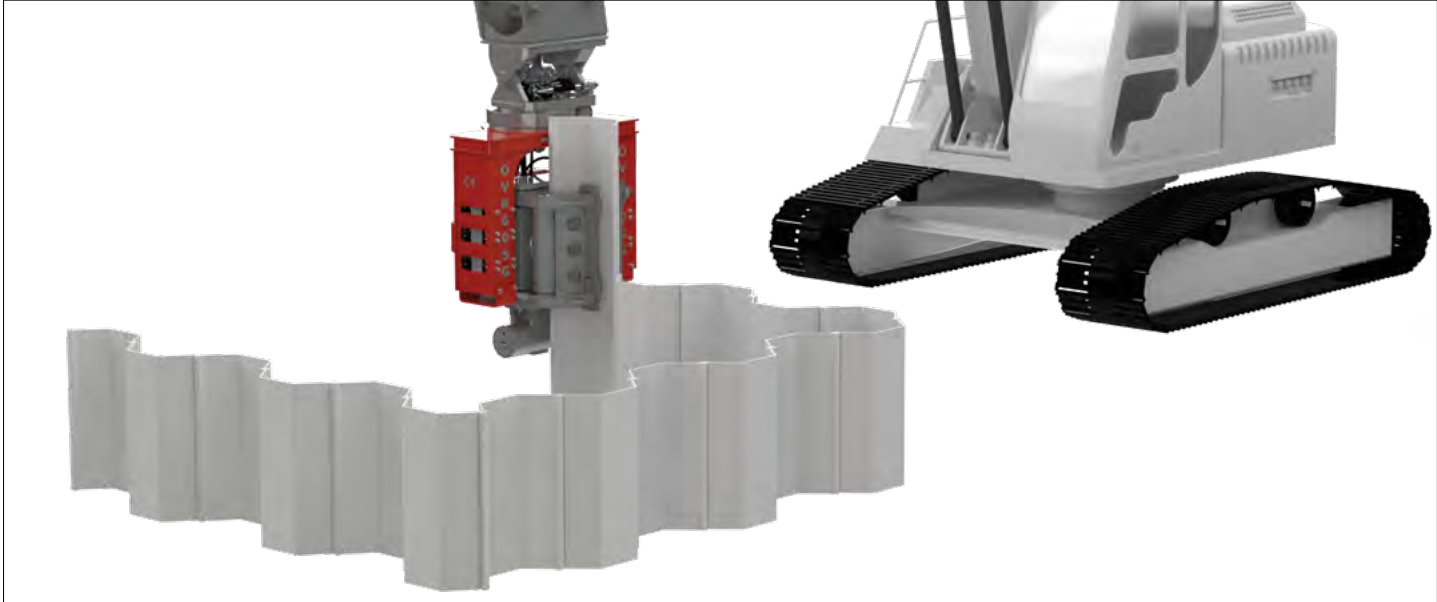

Driving / Extracting (Side Clamp)

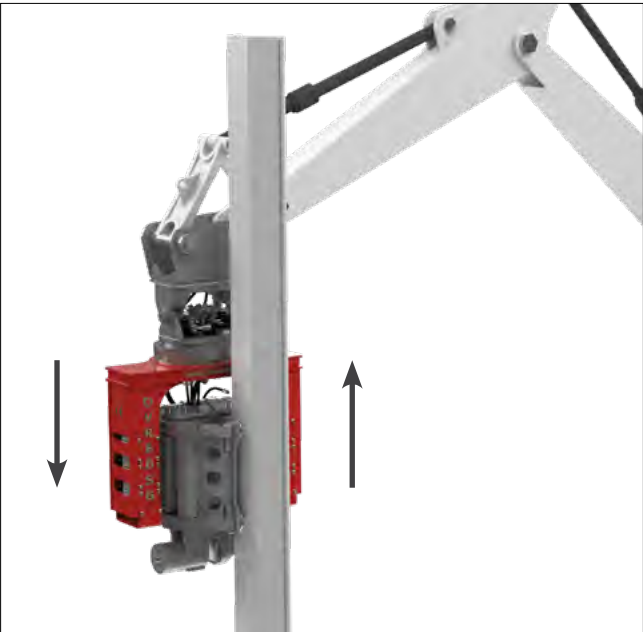

Driving / Extracting (Bottom Clamp)

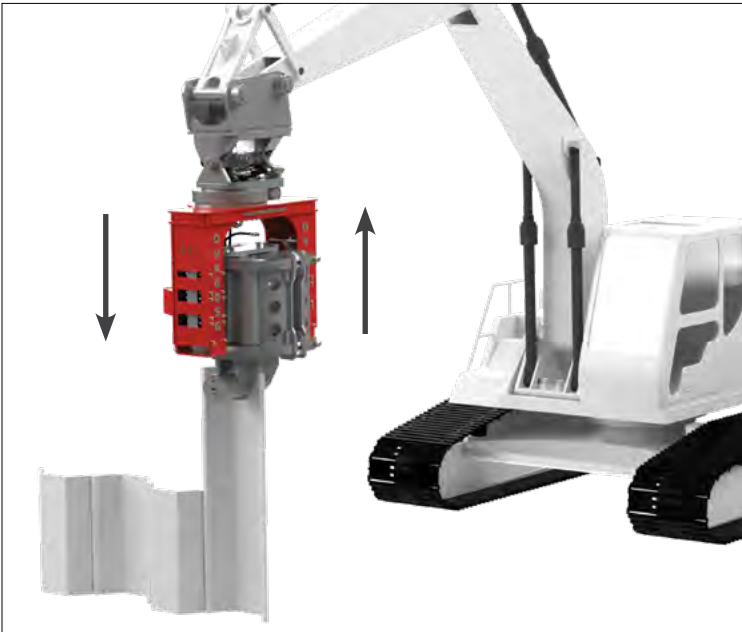

OVR Series[®]

Excavator Mounted Vibro Hammers

Side Grip (SG) SHEET PILE DRIVERS (SG - SP)

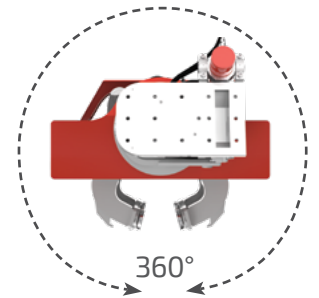
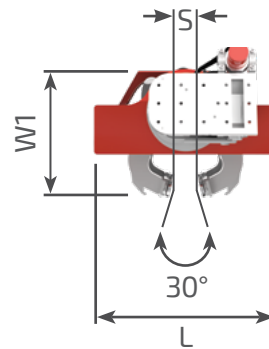
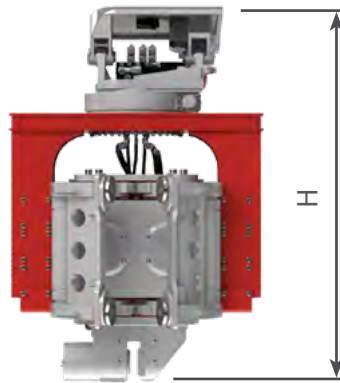
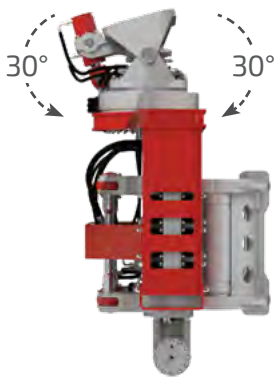

Technical Specifications

Unit	40 SG-SP 40 SG - TP		50 SG-SP 50 SG - TP		60 SG-SP 60 SG - TP		70 SG-SP 70 SG - TP	
	Metric	US	Metric	US	Metric	US	Metric	US
Eccentric Moment (kgm) (in.lbs)	4	347	5.2	451	6.3	547	7.3	634
Centrifugal Force (kN) (tons)	276	31	354	40	434	49	502	56
Frequency (rpm)	2500	2500	2500	2500	2500	2500	2500	2500
Oil Flow (l/min) (gpm)	100	26	150	40	201	53	233	62
Power (kW) (hP)	53	71	80	107	107	143	124	166
Amplitude (mm) (in)	5	0.2	6	0.2	6	0.2	7	0.3
Pulling Force (kN) (tons)	117	13	117	13	177	20	177	20
Side Gripping Force (kN) (tons)	439	49	439	49	532	60	532	60
Bottom Clamping Force (kN) (tons)	292	33	292	33	442	50	442	50

OVR Series[®]

Excavator Mounted Vibro Hammers

Side Grip (SG)

TUBE PILE DRIVERS (SG - TP)

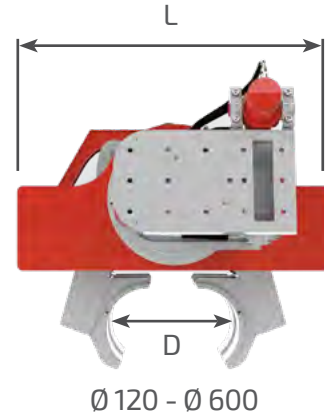
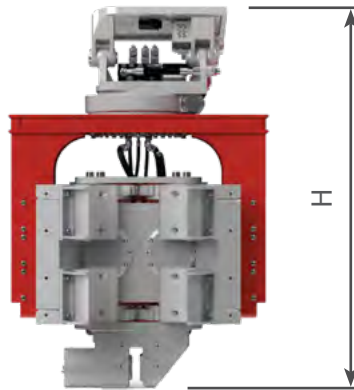

Weight and Dimensions

Unit	40 SG-SP		50 SG-SP		60 SG-SP		70 SG-SP	
	Metric	US	Metric	US	Metric	US	Metric	US
Dynamic Weight (kg) (lbs)	1573	3468	1643	3622	2055	4530	2085	4597
Total Weight (kg) (lbs)	2530	5578	2660	5864	3110	6856	3140	6923
Length / L (mm) (in)	1420	56	1420	56	1450	57	1450	57
Height / H (mm) (in)	2124	84	2124	84	2257	89	2257	89
Width / W1 (mm) (in)	1190	47	1190	47	1215	48	1215	48
Arm Stroke / S (mm) (in)	225	9	225	9	225	9	225	9

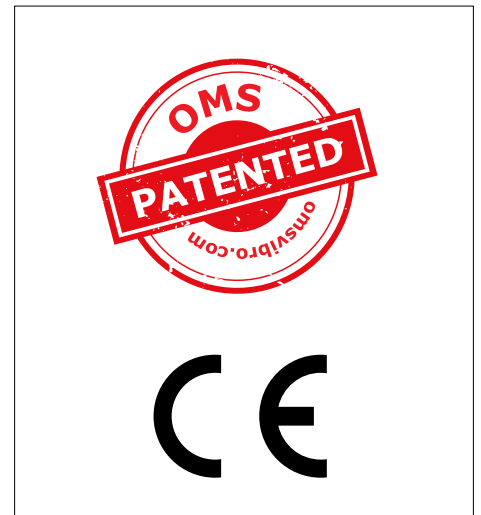



OVS Vibro Website



OVR SG Video



OVS Pile Driving Equipment

 oms@omsvibro.com

 /omsvibro

OVS Side Grip Vibro Hammer - Product Catalog

OVS has the right to change indicated technical data without prior notice.

OVS - SG - R1 - 0825 © All rights reserved.

**ÖZKANLAR
GRUP**

www.omsvibro.com