

OVS GROUND IMPROVEMENT EQUIPMENT

OVS SERIES

Stone Column Equipment

WD SERIES

Prefabricated Vertical Drain (PVD)
Installation Machine



www.ovsvibro.com

POWERFUL GROUND IMPROVEMENT EQUIPMENT BY OMS

Manufacturer of Pile Driving Equipment for over 35 years!

Why Choose the OMS?

OMS offers its nature-respecting and sustainable solutions, which are part of our mission to our customers and business partners in the best way with its quality and the environment of trust it provides. Also, OMS is growing rapidly by including new dealers in its structures while continuing to have a say in international trade. These are the top reasons why OMS is preferred and why we are getting closer to our vision of being situated in the most reliable and respected position in the sector and being the "brand of the future" day by day.



OVF Series Stone Column Equipment

Vibro Compaction (Top Feed).....	4
Tandem Free Hanging	4
Single Free Hanging	4
Vibro Replacement (Bottom Feed).....	7
Drill Rig / Leader Mounted.....	10
Bottom Feed Free Hanging	10
Excavator Mounted Bottom Feed Vibroflot.....	11
Monitoring Reporting	12
Technical Specifications	13

WD Series Prefabricated Vertical Drain (PVD) Installation Machine

Wick Drain Installation Machine	14
Advantages of Wick Drain Equipment	16
Operation Procedure of Installation.....	17
WD 28-43 Technical Specifications	18

We support our customers by recommending the best ground improvement equipment solutions. Vibro compaction and vibro replacement (stone columns), as well as vertical drain (wick drain) equipment, of OMS have proved themselves in the global market from Europe to the Middle East, South East Asia and America continent.

Ground engineering plays an increasingly important role in social and industrial development, especially in connection with major construction projects such as power stations or the expansion of infrastructure systems (railways, harbours, airports, etc.). The objectives of deep vibro compaction and vibro replacement are to improve the strength and deformation characteristics of problematic soils to a certain degree so that structures can be supported safely and economically on or below the improved ground surface.

Vibro compaction and vibro replacement can be another option as technical methods which is used for unfavourable soil conditions that provide a transition between the deep foundation and soil stabilisation. These methods increase the strength of the weak layer and utilise the benefit of improved resistance.

At this point, the OMS provides the right soil improvement equipment as a solution for its customers. The vibro compaction and vibro replacement (stone columns), as well as vertical drain (wick drain) equipment, of OMS plays a crucial role in the market from Germany to the Middle East, South East Asia, and America continent.





VIBRO COMPACTION (Top Feed System)

The OMS vibro compaction method is mostly used in granular soils that are at seismic risk and thus, the method itself is suitable for land reclamation projects to mitigate the risk of liquefaction. This technique is for densifying sand-like soils on site by means of an OMS Vibroflotation probe. With the simultaneous vibration and saturation impact, loose sand particles are repacked into a more compact state and lateral confining pressure within the sand mass is increased.

The vibro compaction technique is most suitable for medium to coarse-grained sand with silt content. Cohesive soil consisting of silt and clay material does not respond to vibratory compaction. The following illustration explains the operation:

The typical OMS configurations of the vibro compaction technique:

1. Tandem Free Hanging
2. Single Free Hanging

The tandem vibro compaction configuration is consisting of two vibroflotation probes suspending from the same crane. It is mostly preferred in land reclamation, railway, highway projects etc. The quality of the compaction/stone column can be monitored with a data logger supplied by OMS. Hence, the depth, compaction rate, time related compaction and withdrawals as well as gravel volume can be measured and monitored.

The single free hanging vibroflotation probe comprises of the same interchangeable parts as the tandem set. The depth of compaction or stone column can be deeper, therefore projects that are medium to small scale are suitable for to be executed with a single free hanging system. Compared to the tandem system, the crane capacity of the vibroflotation probe is slightly smaller. On the other hand, just like a tandem system, the quality of the compaction/stone column can be monitored with a "data logger" so that, depth, compaction rate, time related compaction and withdrawals as well as gravel volume can be measured and monitored.



Operation Procedure of Vibro Compaction

1. Penetration: The OMS vibroflot probe is penetrated to the depth required by the project with the vibration effect and water jet.

2. Compaction: Compaction is a process that continues as the vibroflot is pulled up. The probe is pulled up to a certain level and the ground walls are compressed with an action like penetrating again.

3. Refill: After the ground is slightly compressed, the same as the project's gravel or different type of granular material is poured into the cavity by feeding on the top. The process is continued by moving the probe up and down the soil and vibrating it at the same time.

4. Finishing: After the process is completed, the compacted gravel column and settlement of the soil had achieved.

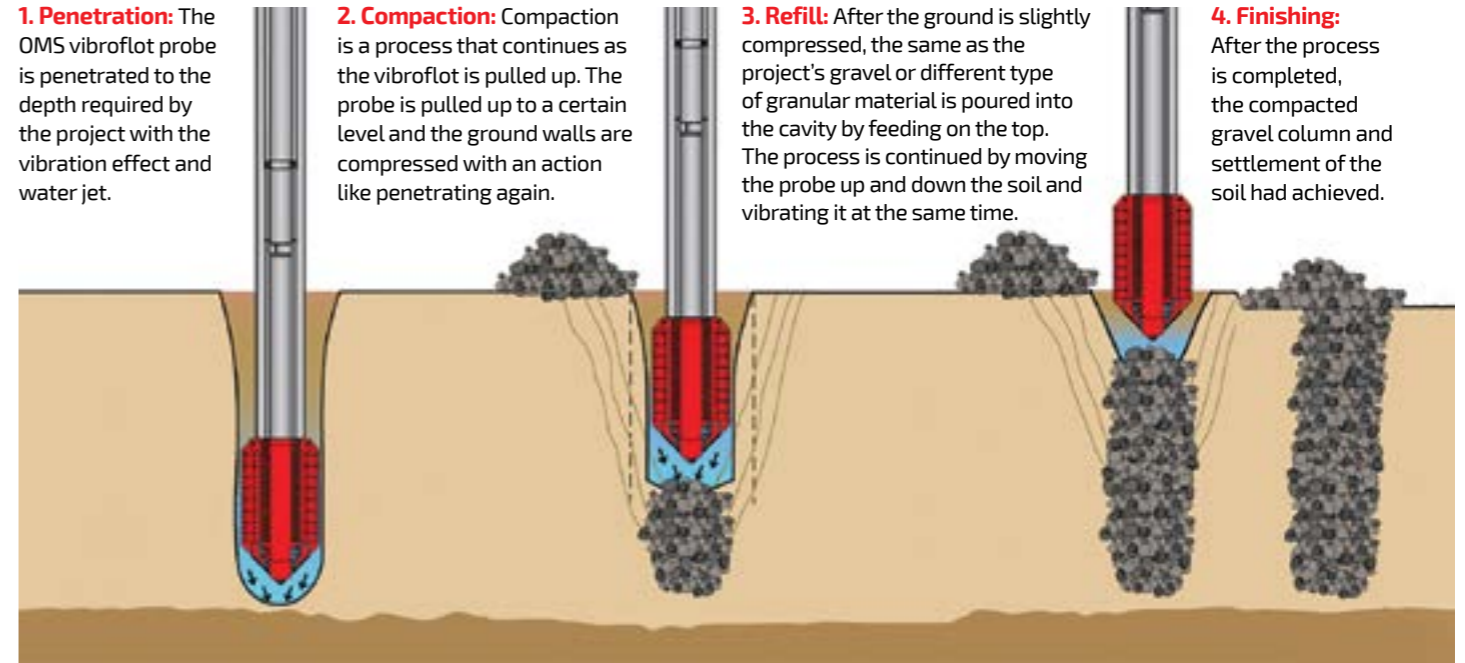

TANDEM FREE HANGING

The configuration of tandem vibro compaction comprises of two vibroflotation probes suspending from the same crane.



SINGLE FREE HANGING

The configuration of single free hanging vibroflotation probe consists of the same interchangeable parts as the tandem set.



VIBRO REPLACEMENT (Bottom Feed System)

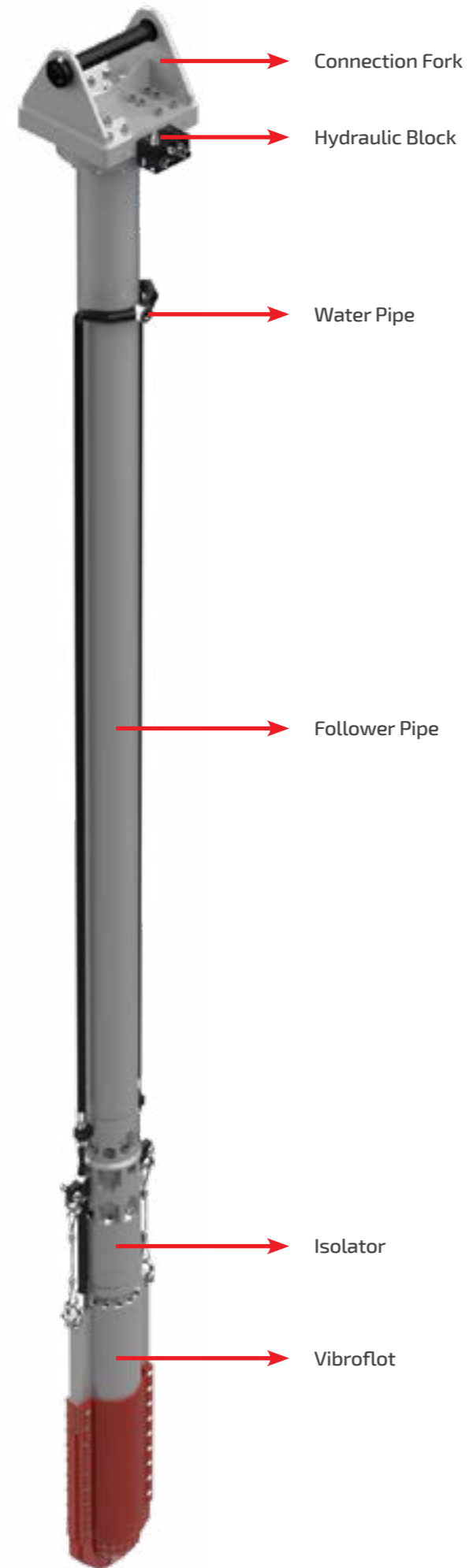

Vibro Replacement Stone Column is a soil improvement system by which vertical columns of compacted gravel are placed into soil. This is a technique that builds load-bearing columns made out of gravel or crushed stones in a cohesive soil and granular soil with high fines content.

Vibro replacement stone columns have been used to improve a wide range of soil from very soft clays and peat to materials marginally suitable for the vibro compaction method. The equipment used for the vibro replacement method is (other than for the vibro displacement method) identical to the one used in the vibro compaction method.

For the operation of vibro replacement columns (stone/gravel columns) "the bottom feed" process feeds gravel to the end of the vibroflotation probe with the aid of pressurised air. For the optimum performance of this process, OMS has developed the vibroflotation probe and gravel hopper with a pressure chamber. These OMS vibroflotation probes can be mounted on an existing drill rig or leader, crane or excavator.



Operation Procedure of Vibro Replacement

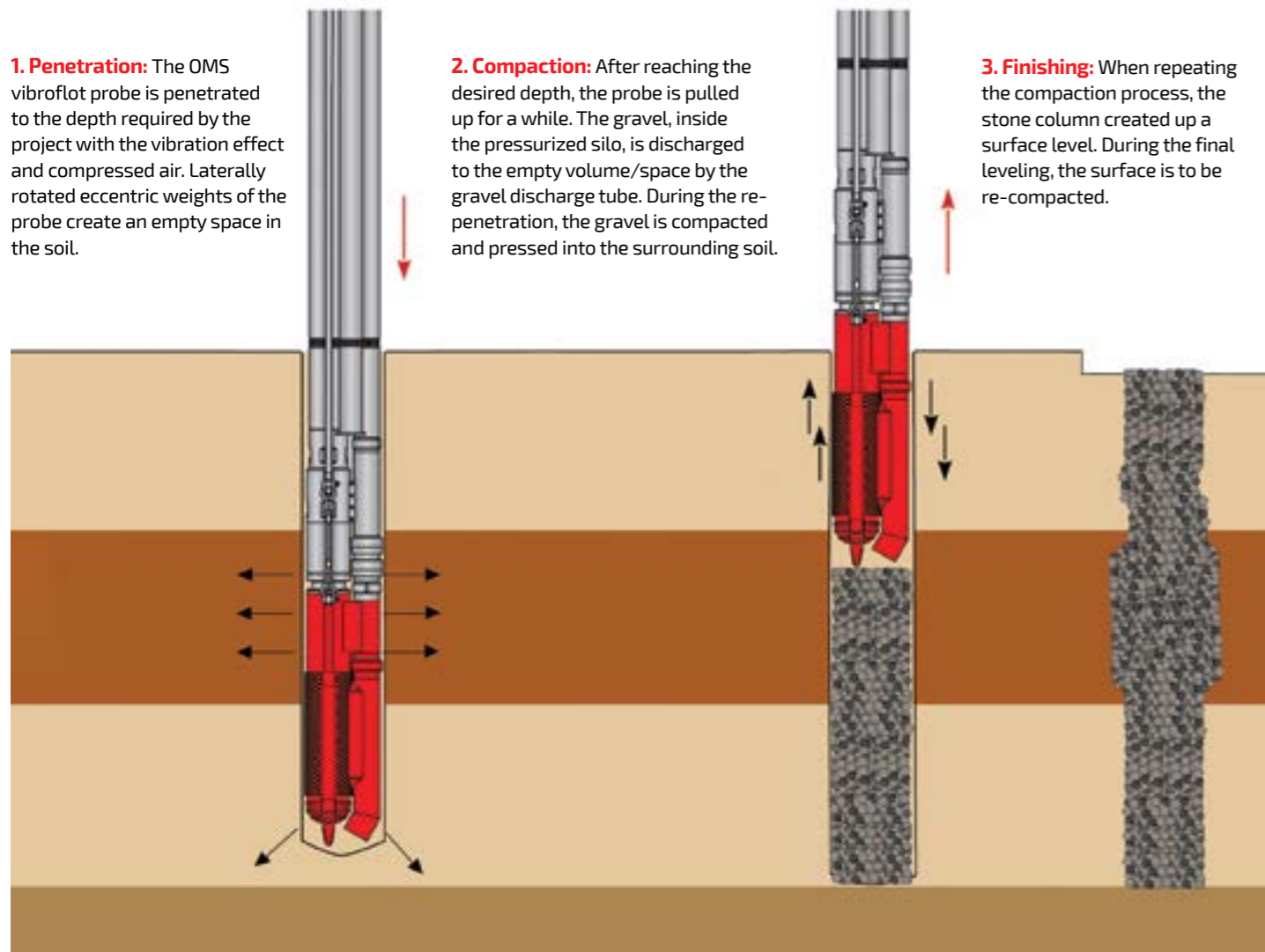

The typical OMS configurations of the vibro replacement technique:

1. Drill Rig / Leader Mounted Bottom Feed Vibroflotation
2. Bottom Feed Free Hanging Vibroflotation
3. Excavator Mounted Bottom Feed Vibroflotation

Typical Configuration of Vibro Replacement

DRILL RIG / LEADER MOUNTED

Probe is easy to mount on an existing drill rig or a leader.



BOTTOM FEED FREE HANGING

Probe with a gravel hopper is suspended by a crane.



EXCAVATOR MOUNTED

Excavator selection is crucial in this configuration.



1. Drill Rig / Leader Mounted

The OMS vibroflotation probe (bottom feed system) with gravel hopper can be easily mounted on an existing drill rig or a leader with a supervisor from OMS technical team. This particular configuration is advantageous since the drill rig or leader is equipped with a pull-down system, thus, allowing additional pull-down pressure to be exerted during penetration and compaction.



2. Bottom Feed Free Hanging

The OMS vibroflotation probe (bottom feed system) with a gravel hopper suspended by a crane. For the configuration, the crane capacity should be suitable to carry on suspended weights.



3. Excavator Mounted Bottom Feed Vibroflot

The OMS bottom feed system is easier to mount on a customer's excavator. In any case, the help of the OMS supervision team is needed. Also, it is simpler to operate and cost-friendly. However, stone columns come with limited depth because excavators have certain limits. Excavator selection is crucial in this configuration. Vibroflotation probe is operated with the excavator's hydraulic system. Depending on the excavator's limitation, the depth of the stone column becomes limited.



Monitoring and Reporting



Monitors, which have a membrane keypad and LCD screen, are placed in a waterproof slot. The operator can control the compression process parameters from the screen.

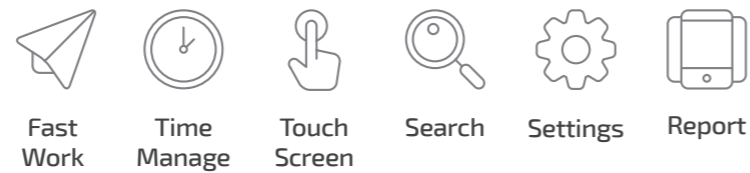

Control Panel of Data Loggers

OMS vibro compaction and vibro replacement outputs can be monitored with a OMS "data logger" system. During the vibro compaction and vibro replacement operation numbers of different sites and parameters are automatically recorded. The following parameters can be measured, saved and printed as proof of production and quantities:

- Date
- Site Name
- Depth of Penetration
- Compaction Point Reference Number
- Compaction Rate (Pressure)
- Volume of Gravel

Technical Specifications

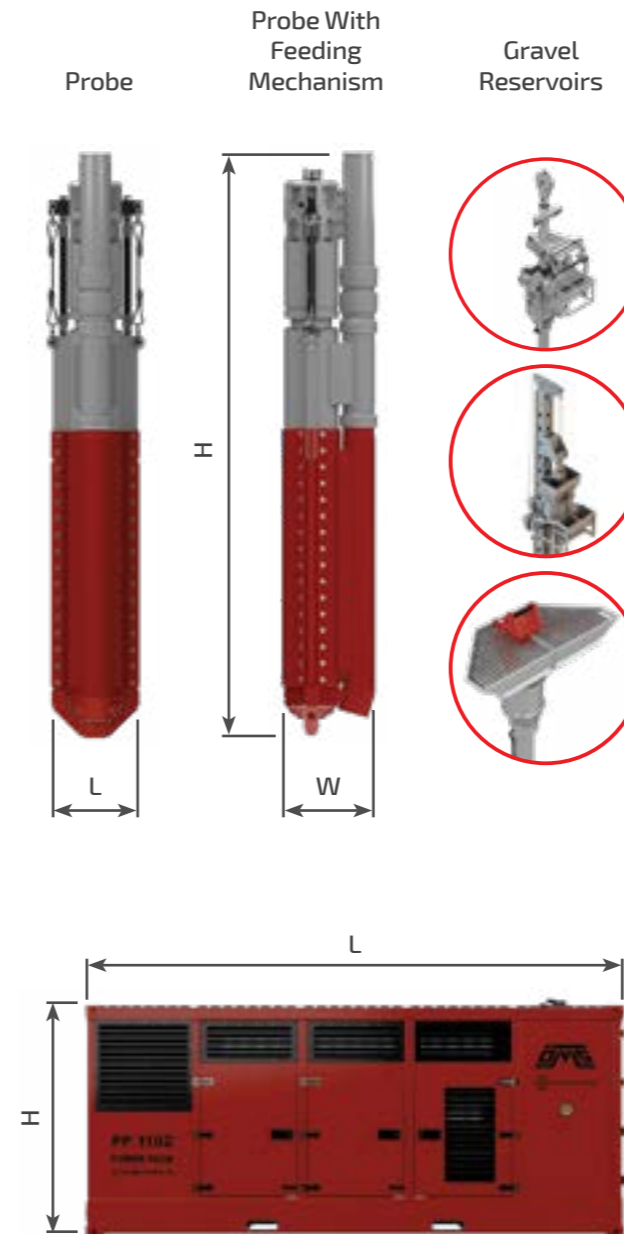
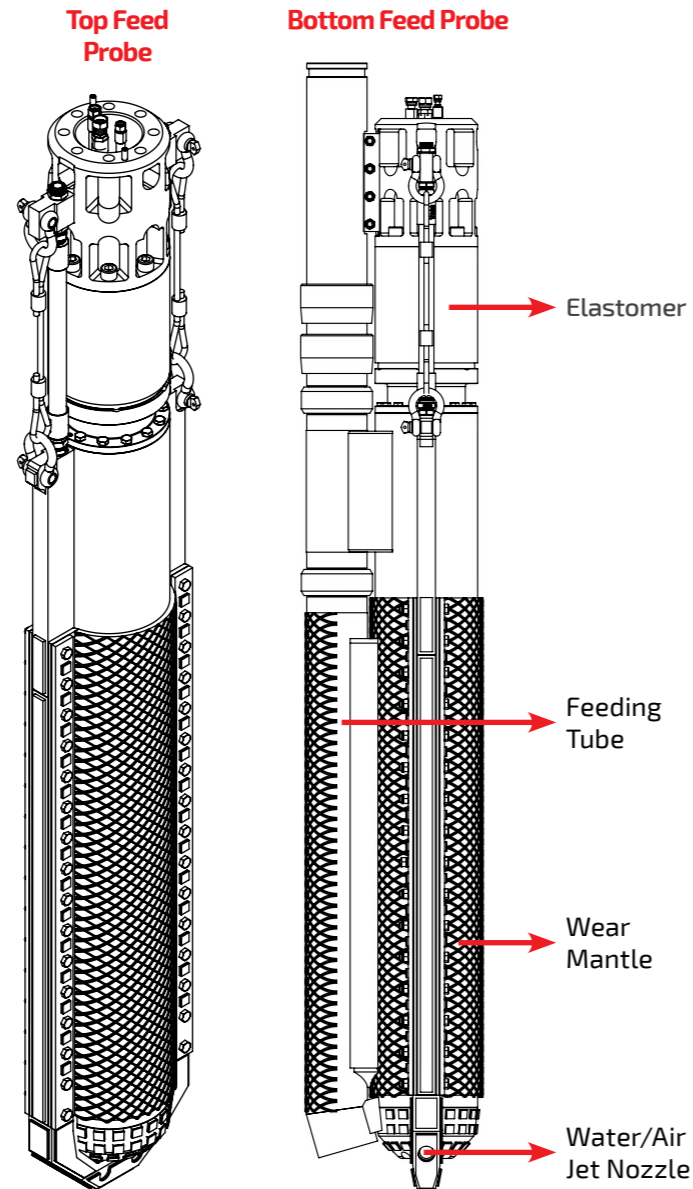

Unit	300-2		300-4	
	Metric	US	Metric	US
Eccentric Moment (kgm / in.lbs)	2	174	4	347
Frequency (rpm / Hz)	3000/50	3000	3000/50	3000
Centrifugal Force (kN / tons)	200	22.5	396	44.5
Oil Flow (lpm / gpm)	180	48	330	87
Power (kW / hP)	105	141	193	259
Power Pack	PP 218		PP 320	
Output (kW / hP)	160	218	235	320

Top Feed Vibroflot

Weight and Dimensions	Metric		US	
	Metric	US	Metric	US
Weight (kg / lbs)	1620	3571	2250	4960
Height / H (mm / in)	2870	113	3560	140
Width / W (mm / in)	376	15	376	15
Length / L (mm / in)	560	22	560	22

Bottom Feed Vibroflot

Weight and Dimensions	Metric		US	
	Metric	US	Metric	US
Weight (kg / lbs)	2100	4630	2812	6199
Height / H (mm / in)	3745	147	4436	177
Width / W (mm / in)	590	23	590	23
Length / L (mm / in)	560	22	560	22

* Technical specifications are calculated on maximum pressure and oilflow base. Required flow and pressure can be set according to the needs.

Unit	PP 218		PP 320	
	Metric	US	Metric	US
Oil Flow Max . (lpm / gpm)	232	61	460	121.4
Pressure Max. (bar / psi)	350	5000	350	5000
Oil Capacity (liter / gal)	450	118.8	500	132
Diesel Tank Capacity (liter / gal)	450	118.8	650	171.6
Width / W (mm / in)	1610	64	1660	65
Length / L (mm / in)	3720	147	4230	166
Height / H (mm / in)	1740	69	1750	69

* Power packs are named according to horse power of its engine. Depending on availability of engine, power pack names can be changed.



The most efficient
results at a low cost!..

WICK DRAIN (PVD) INSERTER

Prefabricated Vertical Drain (PVD) Installation Equipment

COMBINED WICK POWER!

- ▶ **STRONG GEAR DRIVER UNIT** installs the PVD material into the soil.
- ▶ **VIBRO HAMMER** reduces the resistance of the ground with vibration.



Advantages of Wick Drain Equipment:

The **OMS Wick Drain Installation Machine** is a soil improvement machine that is used for the quick consolidation of cohesive soils. The machine is consisting of; hydromotors, sprocket gears, a mandrel and a high frequency vibro hammer. It is very useful equipment to drain the water in the cohesive soils, thus, the liquefaction risk is minimal and settlement time is faster than standard procedures.

The difficulties experienced by engineers in the design of structures built on loose and liquid soils have necessitated various improvement methods throughout history. Unpredictable long-term ground settlements cause unnecessary labor and additional costs, as well as a waste of time.

Simple and ordinary ground consolidation works can take quite a long time. This waste of time can be overcome by creating artificial vertical drainage paths through which water flow can be achieved.

The driving and extracting force of the Wick Drain machine is 276 kN, and the combined force (wick drain + vibro hammer) is 711 kN. Related to the enormous static and dynamic force, the machine is stronger and drives deeper. Depending on the soil condition, the machine is faster due to the operation of the mandrel and its speed up to 100 m/min.

Wick drain can be applied in all areas requiring ground consolidation, including the following areas;

- Highway walls, embankments, impoundment,
- Bridge roads, routes and crossings,
- Dams,
- Railroads,
- Airports and harbors, ports,
- Storage tanks,
- Mining waste ponds.

Operation Procedure of Installation Wick Drain

- Wick drains in rolls are installed in the drain drum located on the machine.
- Sand, gravel, or suitable materials are also called drain blankets shortly, are laid on the ground to be placed in the wick drain.
- The system is rigged to a vertical position with the help of an excavator. The product is ready for operation.
- The specially designed button type mandrel is driven to the desired depth by the OMS Wick Drain Installation Machine. After installing the mandrel, PVD material leaves into the ground.
- This operation is repeated at each predetermined drainage. In different areas of application, the depth at which the operation should be performed may vary.
- After the installation of all the drains is completed, the ground should be loaded with earth material required by the project. The groundwater rises to the surface through the drains.

**Stronger,
Deeper,
Faster!**



WD 28 - 43 Technical Specifications

Technical Data WD 28 - 43

Unit	Metric	US
Static (crowd) Force (kN) (tons)	276	31
Dynamic Force (kN) (tons)	435	49
Combined Force (kN) (tons)	711	80
Operating Frequency (rpm)	2500	2500
Pressure Max. (bar) (psi)	350	5076
Oil Flow Vibro Max. (L/min) (gpm)	200	53
Oil Flow Wick Max. (L/min) (gpm)	506	134
Mandrel Speed Max. (m/min) (ft/min)	100	328

Recommended Excavator Working Weight (ton)

45 - 60



Weights and Dimensions

Unit	Metric	US
Suspended Weight (kg) (lbs)	3077	6784
Length / L (mm - in)	2040	80
Height / H1 (mm - in)	3005	118
Height / H2 (mm - in)	436	17
Width / W (mm - in)	920	36

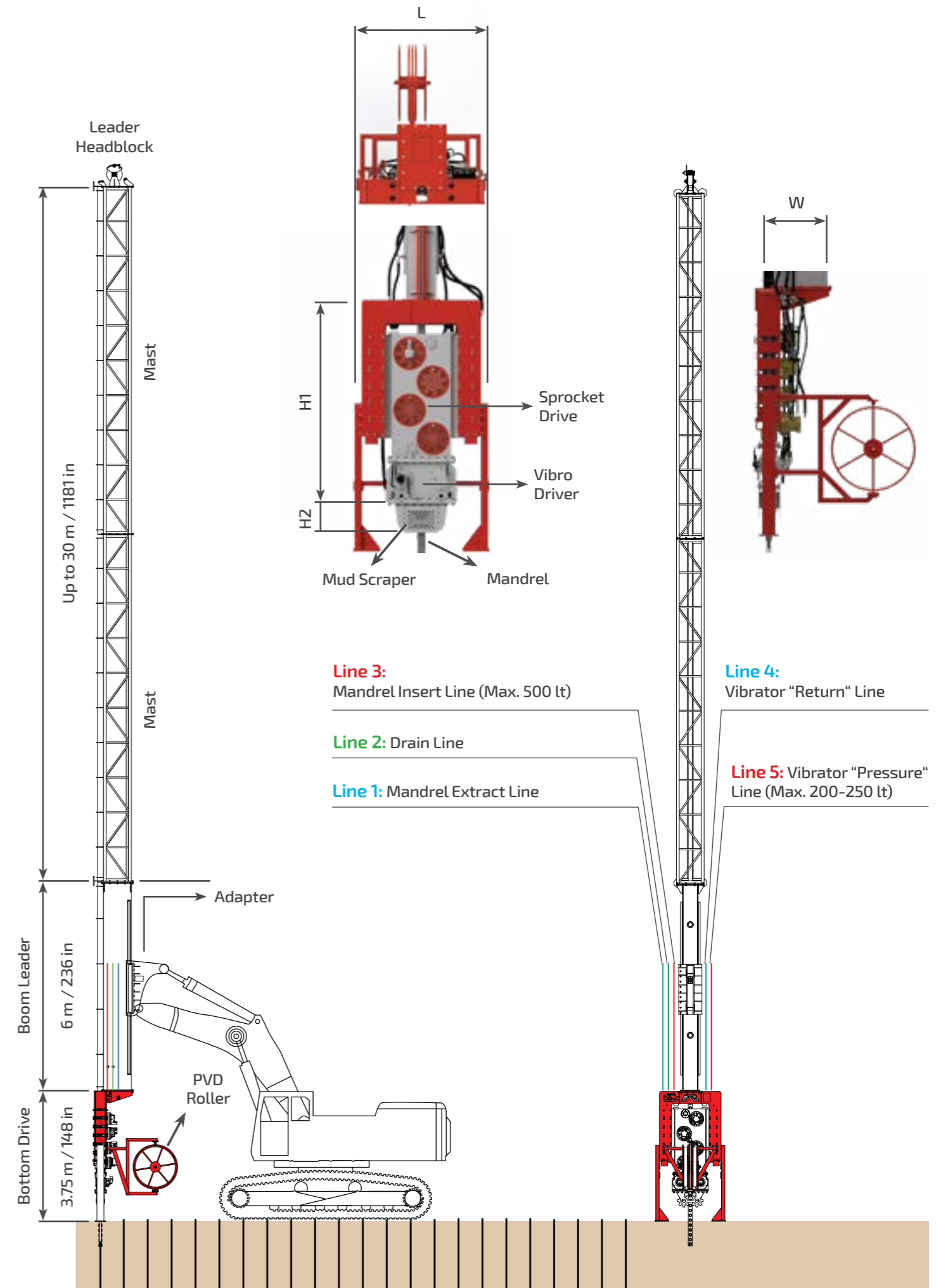
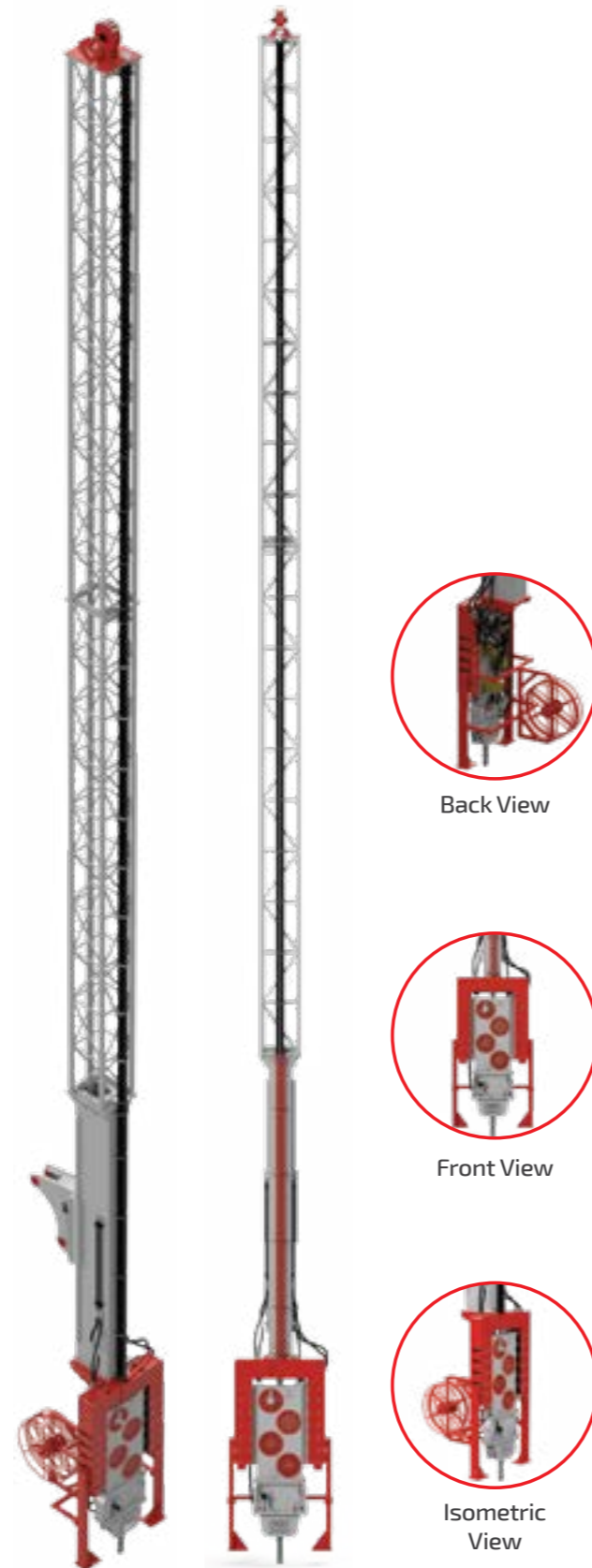



OMS Vibro Website

WD 28-43 Video



OMS Pile Driving Equipment



oms@omsvibro.com



in o f @ X p / omsvibro

OMS Ground Improvement Equipment - Product Catalog

OMS has the right to change indicated technical data without prior notice.

OMS - GIÉ - 0425

© All rights reserved.

ÖZKANLAR
GRUP

www.omsvibro.com